

INVITATION FOR QUOTATION

Ref: Tender Notice No: 8-171/RIFD/RP/POLICY-1/2014-15 dt. 19-04-16/ Tender 1Dt. 13-07-16

Dt:

To,

Sub: Invitation for Quotations for supply of Goods

Dear Sir,

1. You are invited to submit your most competitive quotation for the goods with item wise detailed specifications given at Annexure I,
2. Quotation,
 - 2.1 The contract shall be for the full quantity as described in Annexure I.
 - 2.2 Corrections, if any, shall be made by crossing out, initialing, dating and re writing.
 - 2.3 All duties and other levies payable by the supplier under the contract shall be included in the unit price.
 - 2.4 Applicable taxes shall be quoted separately for all items.
 - 2.5 The prices quoted by the bidder shall be fixed for the duration of the contract and shall not be subject to adjustment on any account.
 - 2.6 The Prices should be quoted in Indian Rupees only.
3. Each bidder shall submit only one quotation.
4. Quotation shall remain valid for a period not less than **90**days after the last date of quotation submission.
5. Evaluation of Quotations,

The Purchaser will evaluate and compare the quotations determined to be substantially responsive i.e. which

 - 5.1 are properly signed ; and
 - 5.2 Confirm to the terms and conditions, and specifications.
6. The Quotations would be evaluated for all items together.

7. Award of contract:

The Purchaser will award the contract to the bidder whose quotation has been determined to be substantially responsive and who has offered the lowest evaluated quotation price.

7.1 Notwithstanding the above, the Purchaser reserves the right to accept or reject any quotations and to cancel the bidding process and reject all quotations at any time prior to the award of contract.

7.2 The bidder whose bid is accepted will be notified of the award of contract by the Purchaser prior to expiration of the quotation validity period. The terms of the accepted offer shall be incorporated in the purchase order.

8. Payment shall be made in Indian Rupees as follows:

Delivery and Installation - 90% of total cost

Satisfactory Acceptance and Training - 10% of total cost

9. All supplied items are under warranty of **12** months from the date of successful installation of Equipment / Test Facility.

10. You are requested to provide your offer latest by **15:00**hours on **26-AUG-2016**.

11. Detailed specifications of the items are at Annexure I.

12. Training Clause (if any) **Yes**

13. Testing/Installation Clause (if any) **Yes**

14. Information brochures/ Product catalogue, if any must be accompanied with the quotation clearly indicating the model quoted for.

15. Sealed quotation to be submitted/ delivered at the address mentioned below,

The Principal, JNTUH College of Engineering Hyderabad, Kukatpally, Hyderabad, Telangana India. PIN: 500085 along with the "Sub: Submission of Quotation for Refrigeration Test Facility under AICTE – RPS Project with Ref: 8-171/RIFD/RP/POLICY-1/2014-15 dt. 19-04-16", to be mentioned on the cover.

16. We look forward to receiving your quotation and thank you for your interest in this project.

(Authorized Signatory)

Name & Designation

FORMAT FOR QUOTATION SUBMISSION

(In letterhead of the supplier with seal)

Date: _____

To:

Sl. No.	Description of goods (with full Specifications)	Qty.	Unit Price	Quoted Unit rate in Rs. (Including Ex Factory price, excise duty, packing and forwarding, transportation, insurance, other local costs incidental to delivery and warranty/ guaranty commitments) (A)	Sales tax and other taxes payable		Total Price (A+B)
					In %	In figures (B)	
Total Cost							

We agree to supply the above goods in accordance with the technical specifications for a total contract price of Rs. _____ (Amount in figures) (Rupees _____ amount in words) within the period specified in the Invitation for Quotations.

We confirm that the normal commercial warranty/ guarantee of _____ months shall apply to the offered items and we also confirm to agree with terms and conditions as mentioned in the Invitation Letter.

Annexure I

JNTUH College of Engineering AICTE Project:

Ref: 8-171/RIFD/RP/POLICY-1/2014-15 dt. 19-04-16

Refrigeration Test Facility to study the effect of nano particle additives to compressor lubrication on COP of the System:

The test facility should be designed for measuring the capacity, COP and power consumption of compressor at various combination of evaporating temperature and condensing temperatures as per the range given below.

The test facility shall have capacity measurement by 2 methods,

- 1. Refrigerant enthalpy method and**
- 2. Calorimetric pot method.**

Specifications of Major Components:

1. COMPRESSOR:

The compressor shall be of capacity 500 ± 10 watts, at -15° C evap temp & 54.4° C condensation temp, displacement 18 ± 2 cc/ rev & RPM 2850 ± 50 .

The operating envelop of compressor should cover evaporating temperature range -17.8° to $+12.8^{\circ}$ C, condensing temperature range $+37.8^{\circ}$ to $+60^{\circ}$ C.

The compressor will be tested in evaporating temperature range -16° to $+11^{\circ}$ C, condensing temperature range $+40^{\circ}$ to $+58^{\circ}$ C.

Test can be conducted with R 134a and with refrigerants that are suitable for the lubricating oil and with pressure temperature relation similar to R 134a.

2. Condenser :

Aluminum finned copper heat exchanger with forced air on heat exchanger. Capacity to test the compressor across the temperature envelop mentioned above.

Provision shall be made to vary the condensing temperature manually between 45° C and 58° C (In an air conditioned room).

3. Evaporator :

Calorimeter pot type evaporator with water glycol as secondary refrigerant, heated by electric heater.

Provision shall be made to vary the evaporating temperature manually between -10°C and 10°C .

Provision for measuring the evaporator capacity.

The evaporator pot heat leakage should be specified.

4. Expansion Valve :

Precise control Swagelok needle valve shall be used to vary or set the suction pressure as per the test requirement. The regulation shall be manual.

5. Electronic Power conditioner :

Constant power supply is most essential for tests. Power conditioner with stability, voltage $230 \pm 1\%$, Frequency $50 + 0.25\%$ and of capacity required to take care of the starting surge of the compressor.

6. Test room:

The test room shall be made of PUF insulation with door to house the test facility where temperature is controlled accurately in the range of 20 to 43°C with a stability of $\pm 0.5^{\circ}\text{C}$. The additional air conditioning heat load produced by test unit in room should be taken into consideration. The dimensions of the room are shown in the figure below.

The gradient in the empty room should be within 2°C .

The test room along with proper housing of air conditioner must be provided.

7. Instrumentation :

The test equipment shall accommodate for measurement of temperature (T) and pressures (P) at various points (compressor discharge, condenser outlet, evaporator inlet & compressor suction). The measurements shall be such that complete refrigeration cycle analysis shall be conducted.

7.1. Mass Flow measurement:

Emerson make electronic flow meter (or equivalent) for Refrigerant mass flow measurement. Refrigerant mass flow meter maximum capacity 70 Kg/hr with resolution 0.1 Kg/hr .

7.2. Temperature measurement :

18 numbers of thermocouples for measuring refrigerant line temperatures, compressor top shell temperature, compressor bottom shell temperature, air temperature at condenser outlet.

2 nos of RTDs for air temperature and water temperature measurement.

7.3. Pressure measurement: 2 nos of Refrigerant pressure transducers for pressure measurement.

7.4. Electrical transducers:

Voltage, current and power : 2 set of transducers of maximum capacity 1000 watts, 230 Volts, single phase.

Frequency : 1 no.

7.5. Datalogger:

30 channels Yokagawa make data logger with Yokagawa software, for temperature, pressure, voltage, current, frequency, power and mass flow rate measurements.

JNTUHCEH:

The following will be in the scope of JNTUHCEH and/or from the project grant:

- Electrical supply for test unit @: 415 VAC + 5%, 50Hz, 3 phase with 4 sq mm copper conductors, the connected power is 4.5 KW.
- Covered well ventilated space : 6.75M x 4 M x 3.5 M
- Soft water & inhibited Ethelene glycol
- Computer, online UPS and Printer for printing reports

Test Room Dimensions:

Top sectional View

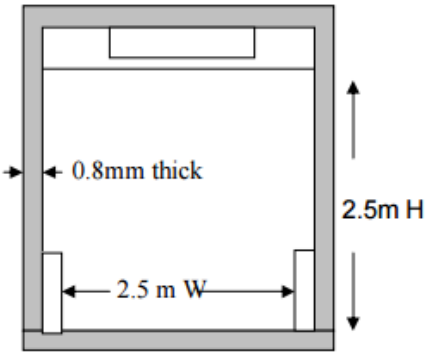

Front sectional view

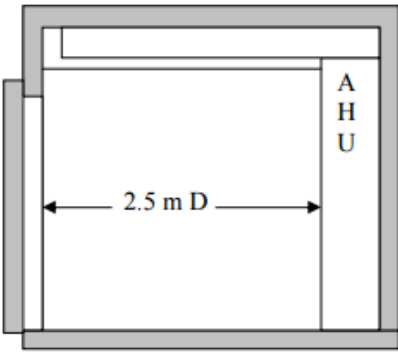

Side sectional view